

**Set includes:**

- Front Splitter
- 14x bolt m6
- 14x secure nut m6
- 14x washer m6
- Installation manual

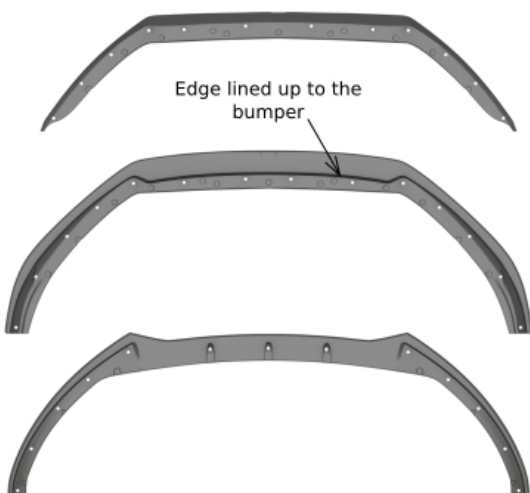

Always match the splitter to the bumper to make sure it fits before the installation.



**WARNING !**  
We strongly recommend to leave the installation to the specialists. Splitter not mounted properly may fall off and cause serious damage.

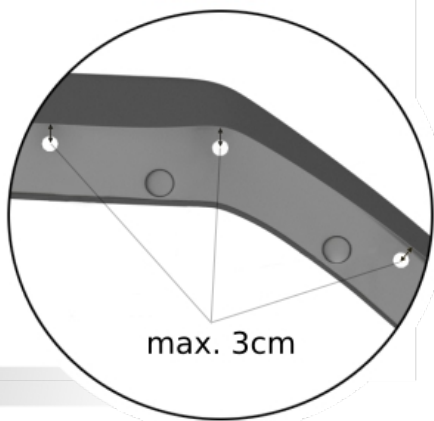

**1. Check the fitting:**

Line up the splitter to the bumper's bottom. Level splitter's edges with the bumper's edges, near the wheels on both sides.

(fitting should be done by two individuals)

**2. Mark drilling points:**

With levelled splitter (pt.1) mark the points through the splitter and the bumper every 15-20cm.

Use 6mm drill to make holes where the splitter connects with the bumper.

**3. Install the splitter:**

Insert enclosed screws through the drilled holes in the splitter and the bumper. Add nuts to secure.

**IMPORTANT !**

**You need to use polyethylene glue if the gap between splitter's edge adjoining bumper and drilled hole is more than 3cm.**

**Glue needs to dry for minimum of 24h before driving.**

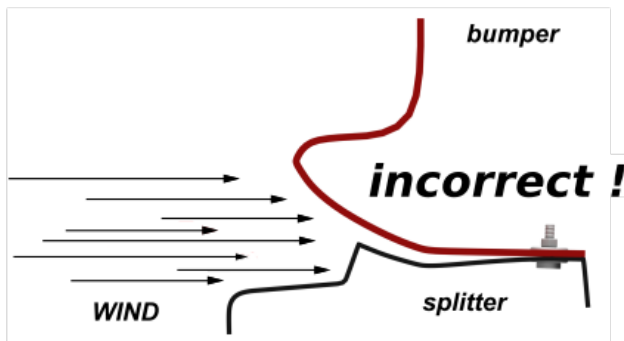
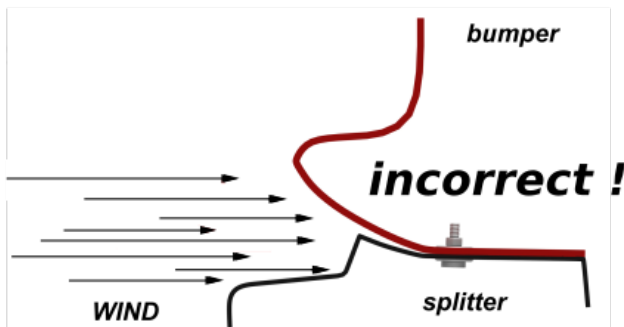
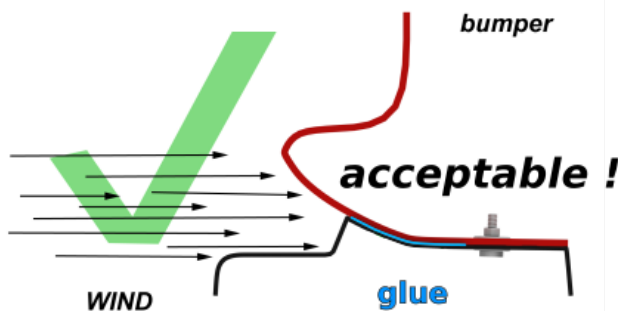
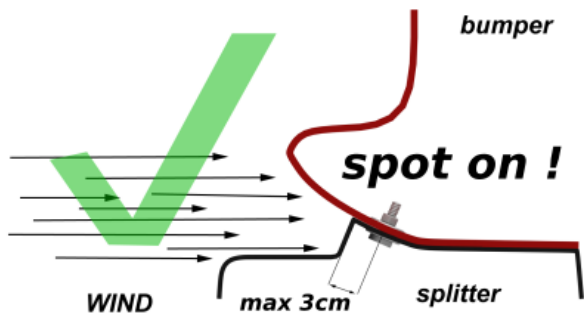

## BEST WAY TO INSTALL SPLITTER

If drilling point is further than 3 cm from adjoining edge add glue into the front gap.

Wind could cause the splitter's damage if the bolt is not installed correctly.